

# DELIVERING AUTOMATION

**CUSTOMIZED SOLUTIONS & EXPERT ADVICE**

YOUR PARTNER IN THE FRAME & TRUSS INDUSTRY

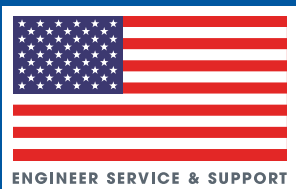

# CUSTOMIZED SOLUTIONS

## / CONTACT US



9555 James Avenue South, Suite 203  
Bloomington Minnesota 55431, USA



+1 763 566 0781



[www.vektausa.com](http://www.vektausa.com)



[info@vektausa.com](mailto:info@vektausa.com)

## / THE VEKTA FAMILY OF SOLUTIONS

Find each product category on the pages below:

### / 01 INFEEED P04

PACKFEEDER; VACUUM LIFTER

### / 02 CUTTING P06

RAZER; P3; RTO; STUD CUTTER; AUTO STACKER

### / 03 OUTFEED P12

DIRECT DELIVERY SYSTEM (DDS); MINI  
MULTISTATION OFK; OFK;

### / 04 FABRICATION P16

AUTONAILER; COMPONENT MASTER; JACK JIG;  
ZERO PRESS

### / 05 CONVEYING P20

STAKPRO FRAME, STAKPRO TRUSS;  
SMART ROLLER; TRUSS TRANSFER; STAKROLLER

### / 06 VEKTA DIFFERENCE P26

VEKTA SUPPORT; VEKTA TEAM

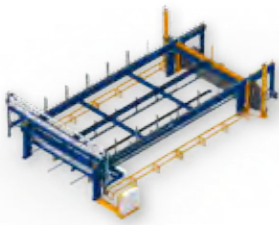

**/ 01**  
INFEEED



**/ 02**  
CUTTING



**/ 03**  
OUTFEED



**/ 04**  
FABRICATION



**/ 05**  
CONVEYING



**/ WHAT ARE YOU TRYING TO ACHIEVE BY AUTOMATING?**

- **ENHANCE EFFICIENCY?**
- **BOOST PRODUCTION?**
- **MINIMIZE WASTE?**
- **ELIMINATE REDUNDANCIES?**
- **IMPROVE SAFETY?**
- **REDUCE OVERHEADS?**
- **FUTURE PROOF?**

**Each answer will be unique to your Truss and Frame plant – with Vekta, the solution will also be unique.**

**/ YOUR PARTNER IN AUTOMATION**

We believe that providing purpose-built solutions and expert support allows us to build a partnership with our customers.

- We listen and take the time to understand your business, your objectives and your ideas
- We foster longlasting relationships well beyond the sales and warranty period
- Your individual needs and circumstances are fully considered and given the highest priority
- We have your back with our expert support
- We want you to be as passionate about automation and Vekta machinery as we are

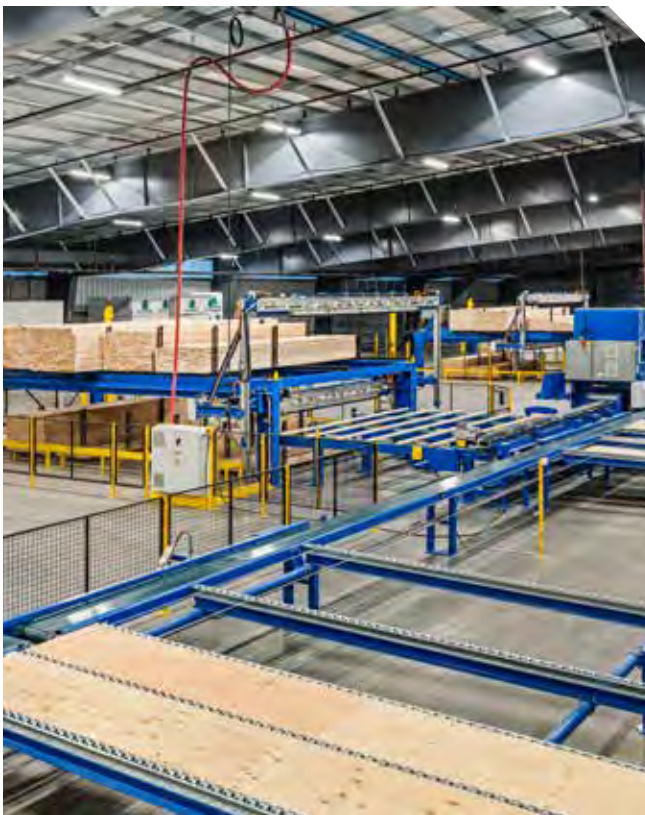

**/ WHAT OUR CUSTOMERS SAY**

“ The team at **Vekta**...were able to open our eyes to **possibilities we didn't know even existed**. The finished product has not only met, but **exceeded our expectations**. With the minimal footprint of the PackFeeder, the **accuracy, speed** and **reliability** of the Razer V5, the speed and **efficiency** of the material conveyor system, and the **overall support** by this team we are **extremely pleased** with the outcome. ”

**/ Josh Wright**  
**V.P. of Manufacturing**  
**The Truss Company, USA**



# INFEED

Fully customizable infeed automation solutions that eliminate risk, human error and can keep up with the speed of your saw.

## VEKTA PACKFEEDER

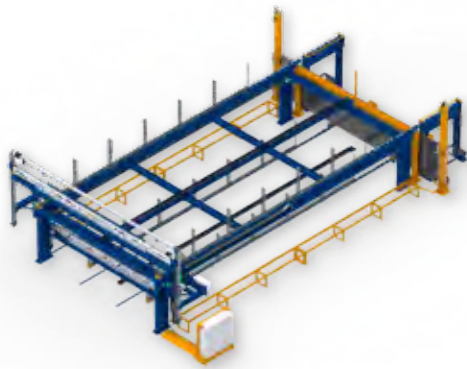

### / SUMMARY

Your saw is only as fast as its feed – manual loading leads to downtime, fatigue, and costly errors.

With the smallest footprint on the market, Vekta's compact dual-level PackFeeder intelligently scans, selects, and delivers boards to the saw at lightning speed – eliminating excess inventory, transportation and waiting times.

### / FEATURES

- Requires ≈75% less space than equivalent systems
- Dual-level design allowing for different size packs with optimal space utilization
- Flexible loading – option to split packs and reconfigure bunk sizes to maximize versatility

### / VEKTA vs THE COMPETITION

- The illustration to the right highlights the amount of floor space required for an equivalent size bunkfeeder incorporating typical 14 USA sized packs of lumber (approx. 75% less)
- The PackFeeder was developed specifically to keep up with high-speed linear saws (like the Razer), as such, it has unmatched speed, accuracy and reliability

### / TOP VIEW

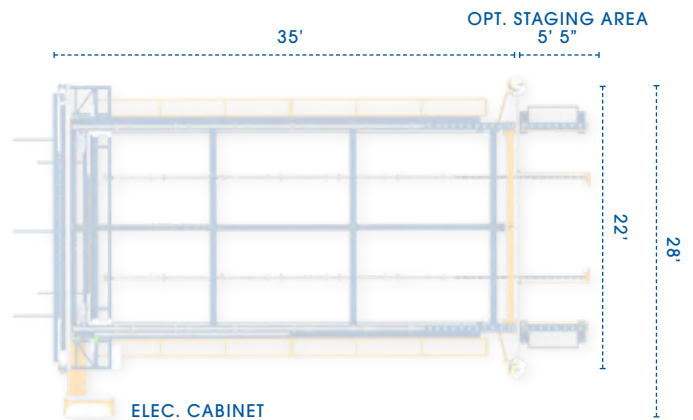

### / SPECIFICATIONS

Max. number of packs	24*
Typical pick cycle time	15 secs (up to 2 boards at a time)
Standard PackFeeder sizes (number of bunks)	14 USA sized*
Supported lumber sizes	Min – 2"x3" x 8' Max – 2"x12" x 20'
Power req.	32A @ 415VAC / 480VAC

\* Total number of packs dependent on the physical size of the packs used

### / OPTIONS

- Integratable with third party saws
- PackFeeder staging area for quicker lumber restock
- Stand-alone versions available
- Various sizing options available

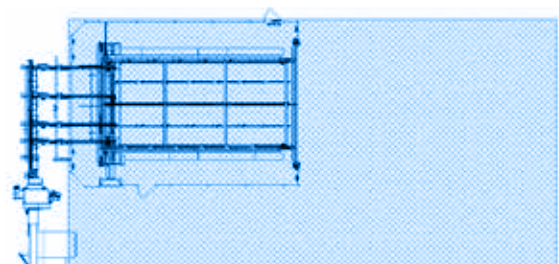



**/ INFEED**

**VEKTA  
VACUUM LIFTER**



**/ TOP VIEW**

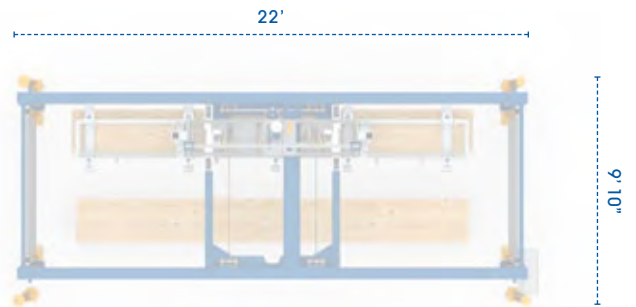

**/ SUMMARY**

The Vacuum Lifter can be used to stack or destack lumber using vacuum heads – enabling one piece or one layer of lumber to be stacked at a time.

The Vacuum Lifter is a robust, reliable, economical and user-friendly solution to stacking and destacking your lumber.

**/ SPECIFICATIONS**

Lumber size	up to 3' 11" wide x 4" high
Pack size	up to 3' 11" x 3' 11"
Lumber length	1' 8" – 19' 8"
Speed capacity	2 layers per min.

**/ FEATURES**

- Vacuum heads with automatic shut valves standard
- Touch screen operation
- Pack tallying
- Integrated self-diagnostics system

- Internet ready for remote diagnostics
- Heavy and robust construction

**/ OPTIONS**

- Fillet / stick sweeper (removal) optional

**/ WATCH**

- Scan the QR code to the right to see the Vekta PackFeeder in action!



# CUTTING

Flexible, custom options to suit your needs – Vekta's industry-leading solutions ensure every step of the process is optimized.

## VEKTA RAZER V5



/ SIDE VIEW

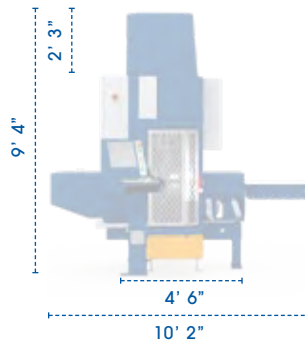

/ TOP VIEW

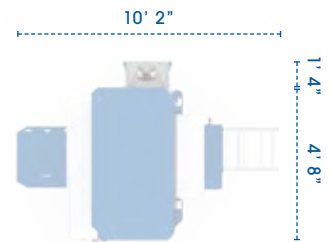

### / SUMMARY

The Razer V5 is the full-featured version of the Razer saw, designed to have maximum flexibility and capability with the ability to perform a huge range of cut types and other functions.

Manufactured to the same exacting standards as the Razer V5, the Razer S5 is simplified to suit a plant primarily interested in cutting common roof truss components and basic, non-raking wall frames. The result is a less expensive linear saw with features tailored specifically to truss plants.

### / FEATURES

- Compatible with ALL NAIL PLATE SOFTWARE
- The industry's smallest footprint
- Customizable to suit your factory processes; material flow, multiple layout options, location of waste conveyor and dust extraction
- Unsurpassable accuracy and precise cutting that ensures products are to correct specifications

### / OPTIONS

- Modular – automated or manual infeed and outfeed options to suit your budget and needs

### / SPECIFICATIONS - RAZER V5

Throughput*	250-350 truss comps. per hour 400-550 frame comps. per hour
Cut accuracy*	+/-1/16" typical
Cutting width - max.	14" (6" for double stacks)
Cutting depth - max.	3 3/4" (single or double stack)
Cutting length - max.	Unlimited
Lumber length - min.	2' 7"
Member length - min.	<1/16"
Main cut angle	0 to 180°
Bevel cut angle**	-67° to +67°
Cut types	Straight, Single/Compound Bevel, Taper, Birdsmouth (zero overcut), Trenching (3 sides), Rip, Bevel Rip, Notch, Drill
Number of cuts per member	Unlimited
Power & air req.	3ph, 415/480 VAC +/- 10%, 50 Amp, 50/60 Hz 340 l/min at 690 kPa (12 cfm at 100 psi)

\* Actual results are site dependent with consideration to lumber condition and member geometries.

\*\* Actual bevel limits based on lumber thickness and saw head tools

- Integrate one or more saws into Vekta's Direct Delivery System



**/ CUTTING**

**/ SAMPLE LAYOUTS**

Flexibility, compatibility, scalability – work with Vekta to develop a comprehensive solution to suit your existing or new plant layout.

Whether you want automated or manual infeed and outfeed options our equipment is fully customizable to suit your factory processes.



**/ AUTO IN/OUTFEED**

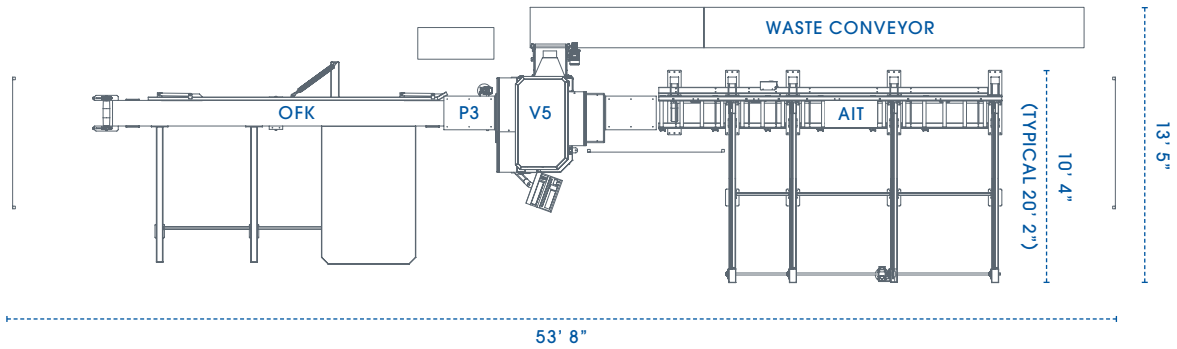

**/ MANUAL IN/OUTFEED**

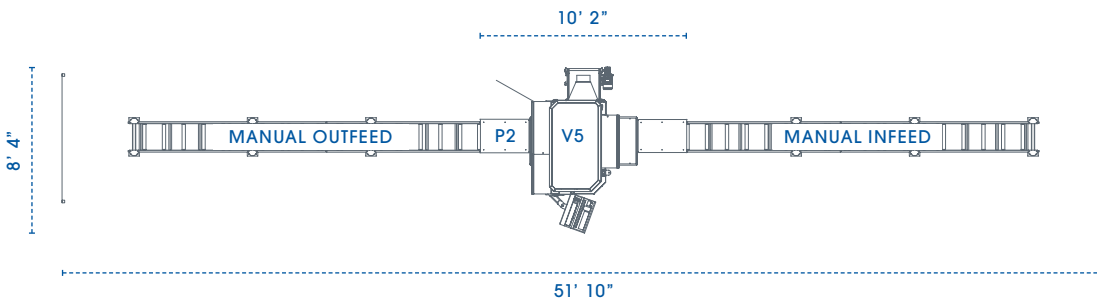

**/ WATCH**

- Scan the QR code to the right to see the Vekta Razer in action!

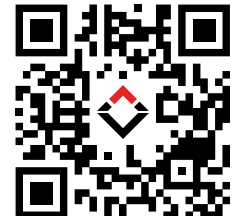



**/ CUTTING**



NAIL PLATE OUTLINES –  
ORIENTATION/POSITION

ORIENTATION & POSITION  
MARK FOR EACH MEMBER

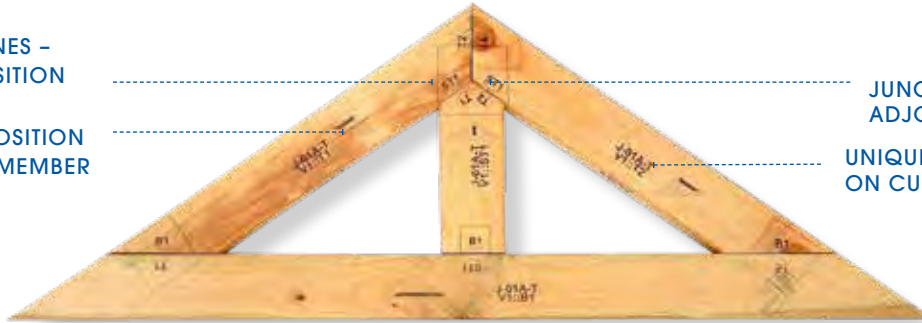

JUNCTION LABELS FOR  
ADJOINING MEMBERS

UNIQUE LABELING BASED  
ON CUSTOMIZABLE RULES

**/ SUMMARY**

Designed specifically for the needs of the Truss and Frame Industry, the P3 printer has been leading the industry for over a decade.

It is a high-resolution, highly configurable option for the Razer saw used to print position-dependent information onto cut components in real-time.

**/ SPECIFICATIONS**

Print resolution	300dpi
Positional accuracy	1/16" typical
Printable faces	2 (top and side)
Printable member length	1/16" – 33'
Print speed max	4' 7"/sec

**/ FEATURES**

- Prints on two sides (top and side)
- Fully configure what is printed on each individual member to minimize waste
- Print logos, checklists, nail plate outline and orientation, assembly information, overhang detail and much more

- Low cost parts and consumable
- Grayscale photo printing (dithering)

**/ OPTIONS**

- Feed direction and fence line configurable







**/ CUTTING**

# VEKTA REAL-TIME OPTIMIZATION

AGILE JUST-IN-TIME  
PRODUCTION

REAL-TIME  
ADJUSTMENTS & RECUTS



SINGLE OPERATOR  
MULTI-SAW MANAGEMENT

CONTROL THE SYSTEM  
FROM ANY DEVICE

**/ SUMMARY**

Vekta's innovative Real-Time Optimization (RTO) software leverages decades of technology advancements and intelligent algorithm development to facilitate Just-In-Time delivery and provide unparalleled flexibility and control of your cutting and production planning.

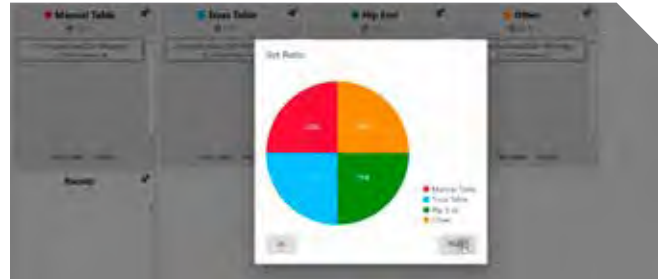

**/ FEATURES**

- Simultaneous optimization – instantly optimize multiple jobs together across assembly stations, minimizing waste
- Decentralized interface – empower your jig operators with the ability to schedule zero-disruption recuts, without the saw operator, directly from the point-of-use. Load, adjust, reorder and reroute jobs in real-time from any network device

- Real-time adjustments – adapt cutting volumes and flow to meet dynamic point-of-use demand
- Multi-saw management – efficient single operator control of multiple saws, reducing labor requirements and costs
- Continuous cutting lists – eliminate end-of-file waste through seamless job transitions, optimizing material usage

**/ OPTIONS**

- Simple kick-off rules to control your point of use needs
- Direct delivery systems designed and custom-built to your plant and delivery needs

**/ WATCH**

- Scan the QR code to the right to see Vekta's Real Time Optimization in action!

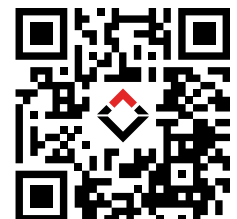



**/ CUTTING**

**VEKTA  
STUD CUTTER**



**/ TOP VIEW**

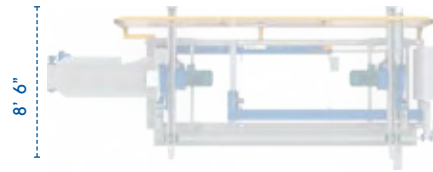

**/ FRONT VIEW**

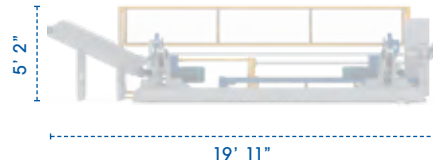

**/ SUMMARY**

The Stud Cutter is designed to accurately cut studs to set lengths at high speed.

The studs are loaded manually, one to four pieces at a time, and can cut up to 60 pieces per minute with an accuracy of +/- 0.2mm (less than 1/64"). The Stud Cutter can be supplied with an automated outfeed stacker to make it a one-person operation.

**/ SPECIFICATIONS**

Lumber size	2"x2" to 4"x4"
Lumber length	8' to 12' 9"
Cut stack	Up to 4 pcs/lug
Chain lugs	15 lugs/min.

**/ FEATURES**

- Servo positioning of saw to accurately cut to length, +/- 0.2mm (less than 1/64")
- Full guarding to obtain maximum operator safety
- Touchscreen display with cutting management, diagnostics, saw positioning, and job allocation
- Waste conveyor for offcut removal
- Standard TCT sawblades used
- Heavy and robust construction

**/ OPTIONS**

- Pair with the Auto Stacker and/or infeed options for increased productivity



**/ CUTTING**

**VEKTA  
AUTO STACKER**

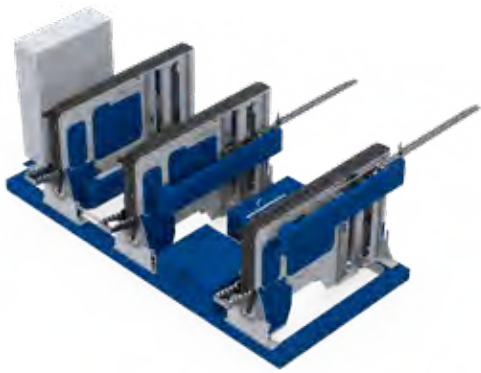

**/ SIDE VIEW**

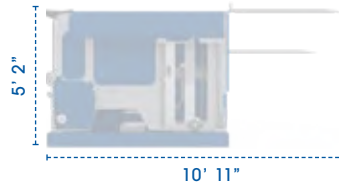

**/ FRONT VIEW**

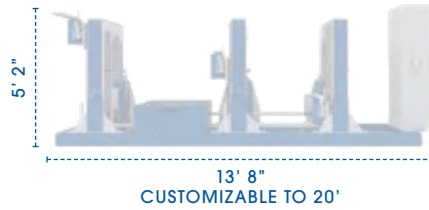

**/ SUMMARY**

The Auto Stacker is the perfect solution to continuously stack lumber into packs without supervision.

This machine is ideally suited to any moulding, finger jointing or stud cutting line and will improve productivity and safety.

The Auto Stacker is a robust, reliable, economical and user-friendly solution for stacking lumber.

**/ SPECIFICATIONS**

Lumber size	1"x2" to 4"x12"
Lumber length	6' to 20'
Pack size	Min - 2'x2'
Throughput	2-3 layers/min or 20 pcs/min.

**/ FEATURES**

- Ability to have heads moveable
- Fillet / sticks optional
- Touch screen operation
- Pack tallying
- Integrated self-diagnostic and remote-diagnostic systems
- Heavy and robust construction

**/ OPTIONS**

- Pair with a pack outfeed conveyor for improved throughput

# OUTFEED

Vekta's custom outfeed solutions deliver cut members where you want, in the correct orientation and order for easy assembly.

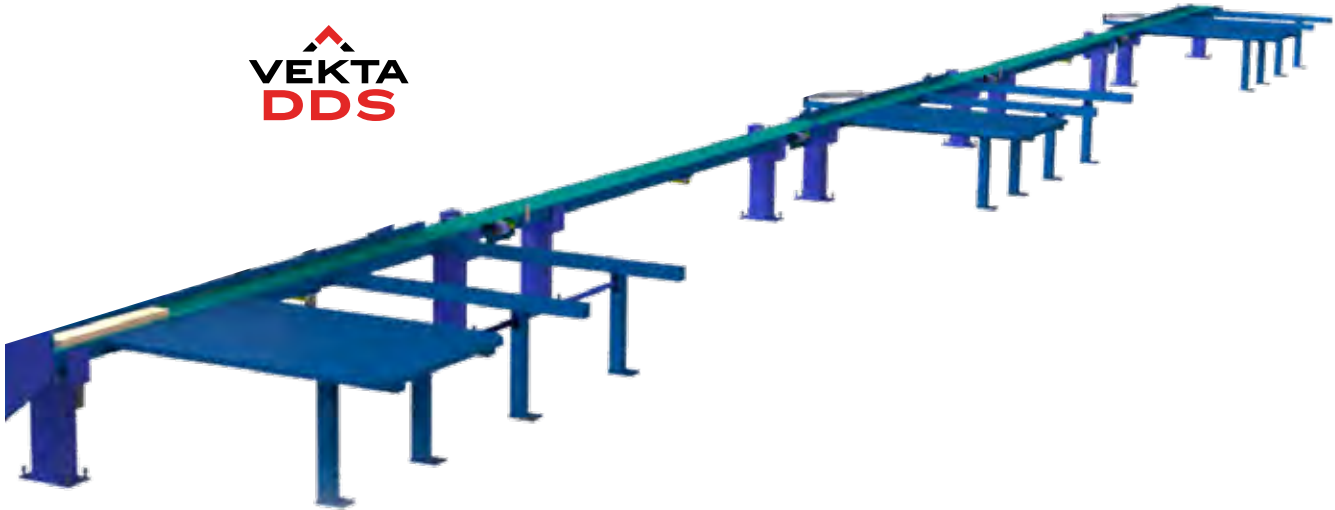

## / SUMMARY

The Vekta DDS (Direct Delivery System) is highly configurable and optimizes one of the most labor intensive, least efficient steps in a plant – delivering cut components from saw to jig for assembly. Easily maintained and repaired, there is no need to hire engineers to maintain the equipment.

Utilize Vekta Real-Time Optimization (RTO) software to schedule and optimize together multiple jobs at once and reduce operator intervention whilst retaining control.

## / SPECIFICATIONS

Number of kick-off locations	1 - 99
Layout of conveyor line	Customized
Kick-off options	Single, Single Destack, Dual Direction, Dual Direction Destack, Transfer
Table options	Gravity, Powered, Standard
Power & air req.	415 / 480VAC @ 32A 15 CFM @ 100psi

## / FEATURES

- Highly configurable to suit new and existing factory layouts
- Accepts cut components from one or more saws
- High speed rotation options for moving components to a conveyor line that is 90° to the first conveyor
- Ability to split the conveyor into multiple lines feeding in different directions
- Dual and single direction kick-off mechanisms can be positioned anywhere along the conveyor lines
- All cut components are justified to suit the kick-off locations and factory layout
- Powered and unpowered tables
- Printing location and orientation based on how the member will be picked up at point-of-use
- Kick-off components based on configurable rules (type of member, location in truss/frame, dimensions)
- With Just-In-Time delivery, start assembly moments after cutting commences – no need to cut all or most of a job before assembly begins
- Maximum safety with minimal labor and maintenance
- Operation and safety solutions customized for each and every installation – not a one-size-fits-all approach
- Interface at console and/or portable tablet



**/ OUTFEED**

**/ SAMPLE LAYOUT**

Fast, accurate and safe – work with Vekta to develop a comprehensive and customized DDS solution to streamline your factory.

**/ TOP VIEW**

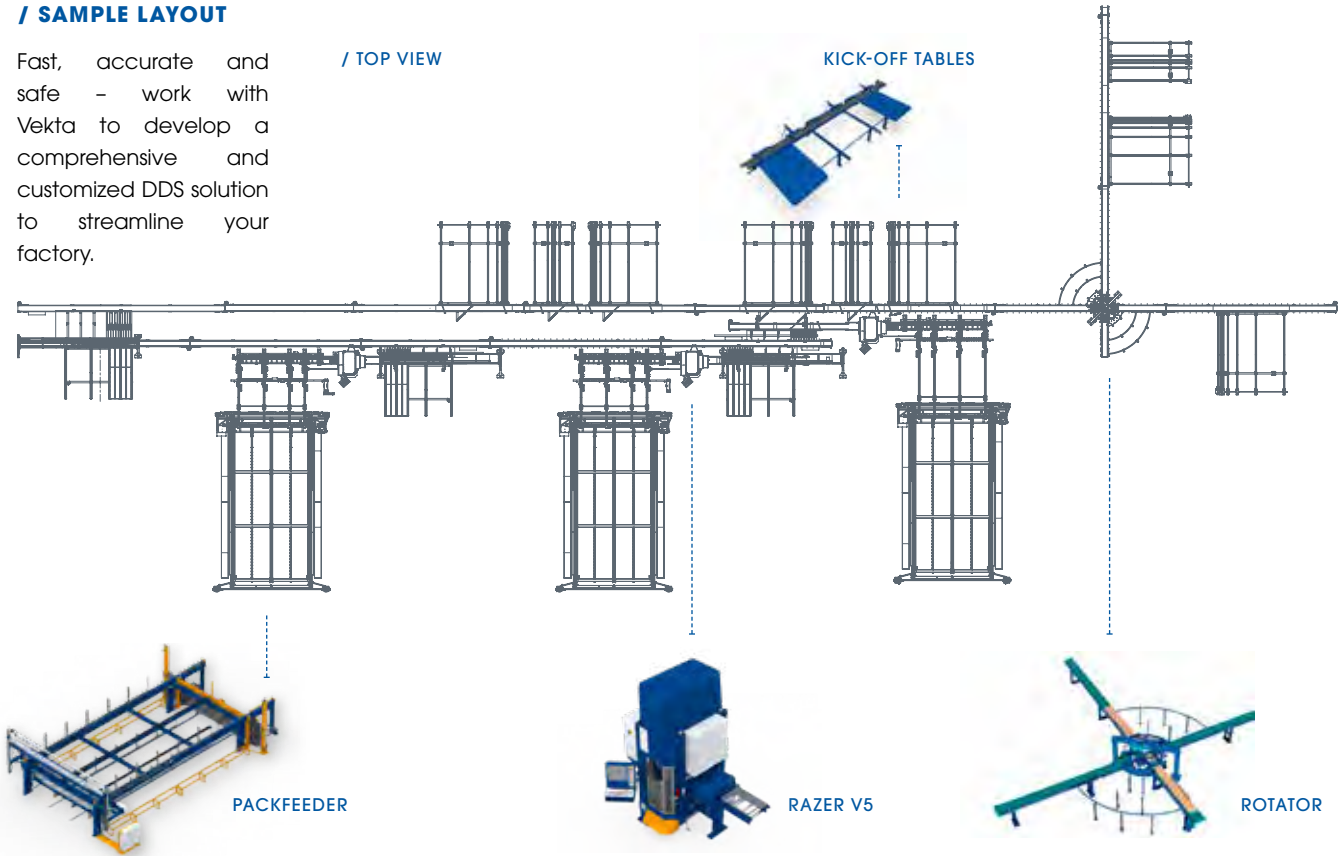

**/ OPTIONS**

- Scalable – add more conveyors and/or kick-offs in future as needed
- Customizable system designed and built specifically for your site
- Designed to work with real-time optimization and just-in-time delivery. Utilize these features to automate many traditionally manual processes
- Multiple kick-off and direction options



**/ WATCH**

- Scan the QR code to the right to see Vekta's Direct Delivery System in action!





**/ OUTFEED**

  
**MINI MULTISTATION OFK**

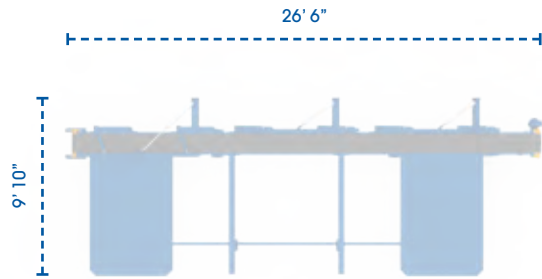

**/ SUMMARY**

Increase your efficiency and flexibility without sacrificing floorspace.

The Mini Multistation Outfeed Kick-off (OFK) gives you a second full-size kick-off area: separate your cut members by job, type, length and reduce your sorting time on the outfeed.

**/ FEATURES**

- Simple rules to govern the kick-off location of your members, offcuts, reuse, and waste
- Cut two jobs at once and kick to different locations or split your components by whatever means suits you
- Minimal maintenance & easy to source spares

**/ OPTIONS**

- Extended safety options including e-stop lanyards, switches and light curtains always available and can be added later
- Upgrade to a dual direction kick-off to push members in both directions after cutting (de-stacking capability available)
- Easily change your kick-off rules at any time to suit the job

**/ SPECIFICATIONS**

Kick-off cycle time	<2 secs
Max. delivery locations	4 (kick-off 1, kick-off 2, middle between tables, off end)

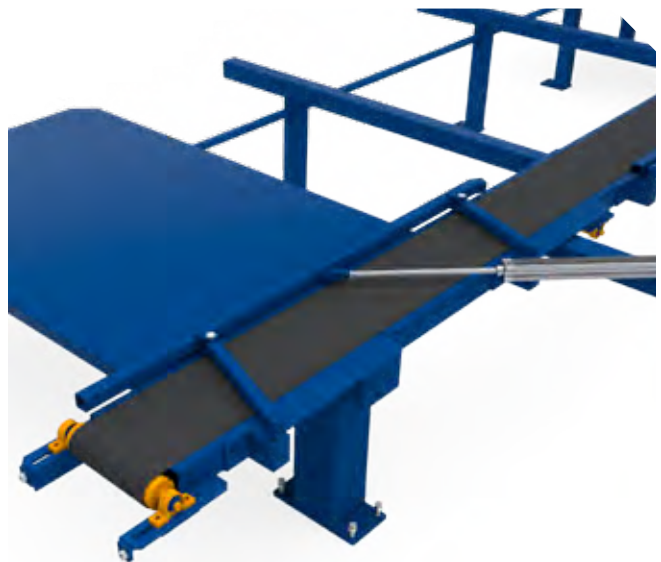



**/ OUTFEED**

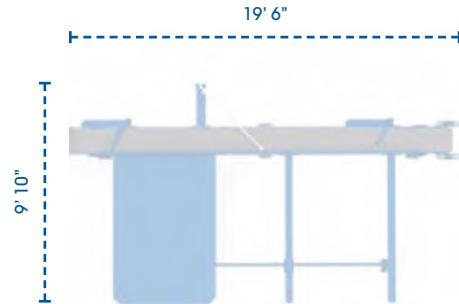

**/ SUMMARY**

Vekta Outfeed Kick-off (OFK) offers versatile outfeed solutions to complement high-speed linear saw cutting.

Single kick-offs built to a specific orientation and shape, or upgrade to a Direct Delivery System (DDS) complete outfeed solution.

**/ SPECIFICATIONS**

Height - overall from floor	2' 12"
Lumber length to destack	1' 7" - 20'
Kick-off cycle time	<2 secs

**/ FEATURES**

- Unlock the full potential of the P3 printer with an intelligent conveying outfeed
- Standard tables can be replaced with gravity roller tables or powered chain kick-offs as required

**/ OPTIONS**

- Single and dual direction kick-off solutions - with de-stacking capability



# FABRICATION

Fully customizable solutions to increase the accuracy and productivity of your frame and truss lines.

## VEKTA AUTONAILER



AUTONAILER WITH 20'  
PROGRESSOR LEGS

STANDARDNAILER  
3' 9"

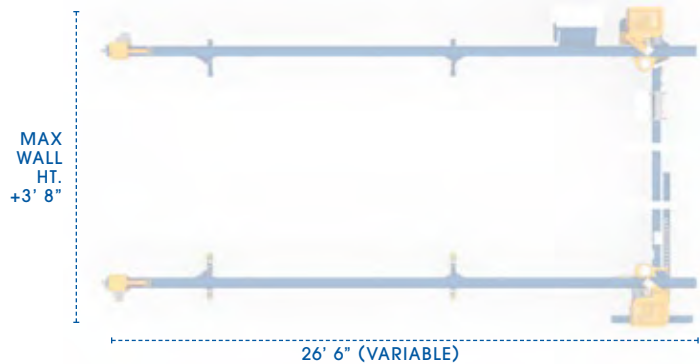

### / SUMMARY

The Vekta AutoNailer is our premium wall panel fabrication system.

With automatic positioning of the wall panels, even the most inexperienced operators can assemble complicated frames.

Intelligently guided via our proprietary software, operators are led through step-by-step whilst keeping track of building metrics and statistics.

### / SPECIFICATIONS

Production capacity per 8 hour shift	AutoNailer: 800-1600 linear ft StandardNailer: 500-1000 linear ft
Cycle time	<3 secs
Min. wall height	4' 11"
Max. wall height	Variable - up to 13' 9" max.*
Max. wall length	AutoNailer: 20' (based on progressor length) StandardNailer: Unlimited
Lumber sizes	2"x3" to 2"x6"

### / FEATURES

- Full integration with our range of conveying, finishing and stacking options
- Vekta's whole framing line requires minimal maintenance and upkeep and can be built to accommodate any size frames or lumber
- One touch clamping and nailing of top/bottom plates

- Intelligent guidance systems - less downtime needed to train new staff and more time spent building
- Full range of complimentary machines that can handle every facet of framing - Nog and Component Masters for stud, fireblock, and internal components (cutting, nailing and delivery)

### / OPTIONS

- Smart touch screen
- Customizable sizing and delivery and outfeed options to suit your plant setup and needs
- \*Size and length option configurable

- Options for cutting all framing components at point-of-use
- StandardNailer also available - our budget frame fabrication system that can be upgraded to the AutoNailer at any time.





**/ FABRICATION**

**VEKTA  
COMPONENT MASTER**

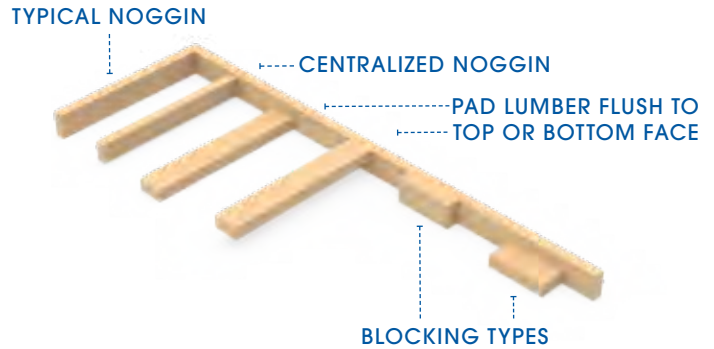

**/ SUMMARY**

The Vekta Component Master is built exclusively to support your wall panel line. Capable of cutting and nailing your wall components as needed and delivered straight to the point-of-use.

Operate in cut, assemble, or cut-and-assemble modes to suit your factory processes. Fabrication of sub-assemblies has never been easier.

**/ SPECIFICATIONS**

Lumber width / height	2"x2" to 2"x6"
Raw lumber / cut stud max length	14 feet
Cutting cycle time Nailing cycle time	3-4 seconds
Cutting accuracy*	<1/16"

**/ FEATURES**

- Small footprint, safe and easy to use
- Highly versatile for all sub-assemblies
- Hybrid operation – accepts pre-cut members or cut from raw lumber
- Highly accurate progressors ensure quality component assembly with minimal human error

**/ OPTIONS**

- Nog Master – a dual progressor variation specifically suited to high speed stud/noggin cutting and assembly also available
- Backwards compatible with future modular upgrades (screwing, drilling)
- Flexible nail gun integration, with larger coil options



**/ FABRICATION**

**/ SAMPLE LAYOUT**

Vekta's custom framing solutions will help you streamline your framing line to give you increased accuracy and productivity.

**/ TOP VIEW**

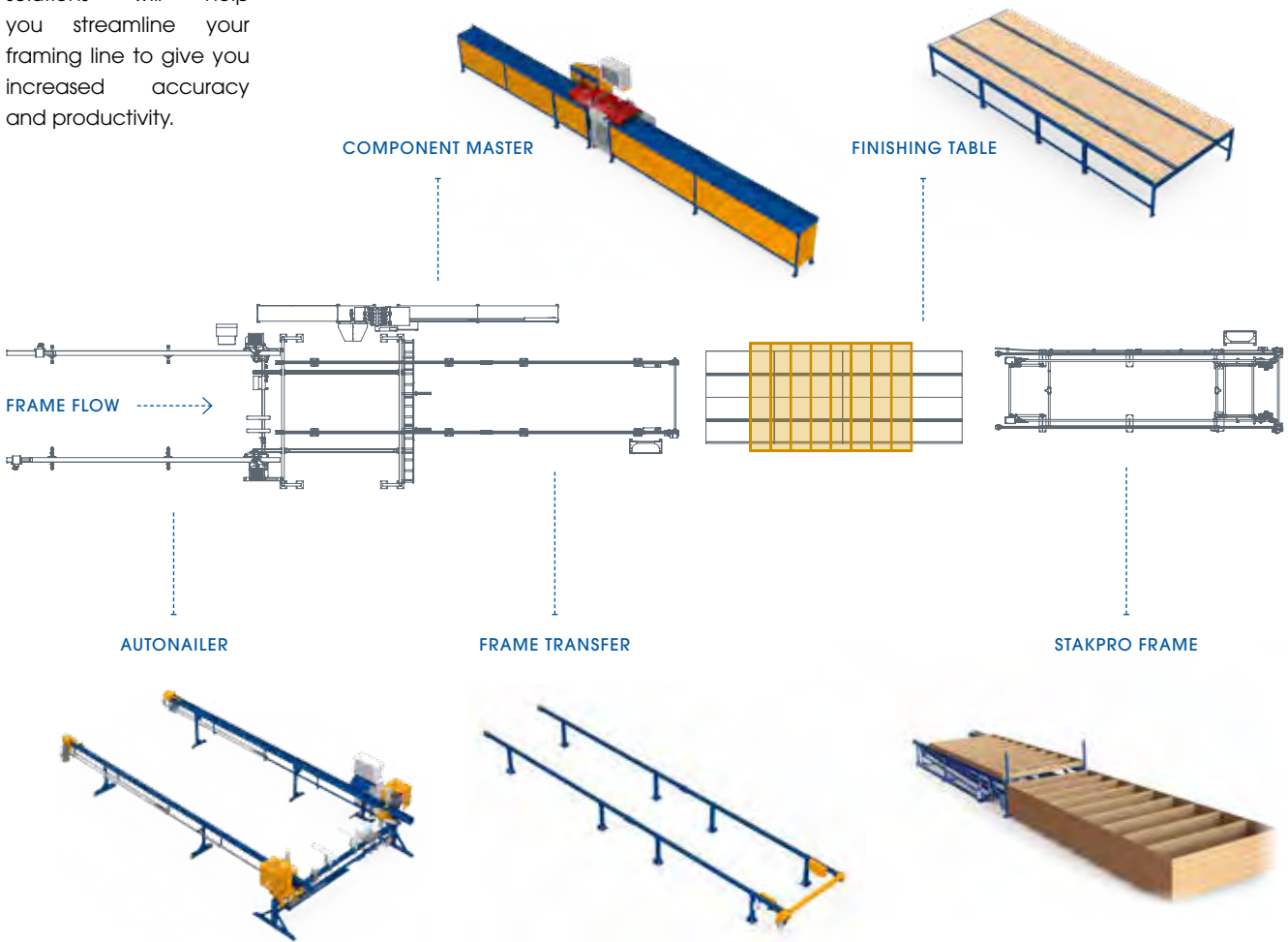

**/ WATCH**

- Scan the QR code to the right to see Vekta's Fabrication solutions in action!

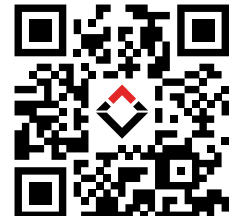



**/ FABRICATION**

**VEKTA  
JACK JIG**



**VEKTA  
ZERO PRESS**



**/ SUMMARY**

The 5 head Jack Jig is a heavy-duty press designed for quick and easy production of Jack and Hip trusses.

The Zero Press is a single head press designed for quick and easy production of trusses.

In both products, truss components are loaded manually then nail plates, fed from a cartridge, are automatically positioned and pressed in under 30 secs (under 20 secs for the Zero Press).

**/ SPECIFICATIONS**

Truss angle	15 to 40**
Pressing force	30000 lbs
Cycle time	Jack Jig: <30 secs Zero Press: <20 secs
Number of press heads	Jack Jig: 5 Zero Press: 1

**/ FEATURES**

- Servo positioning of truss angle +/- 0.5\*\*
- Touchscreen display with truss management, diagnostics, and angle positioning\*
- Full perimeter guarding to obtain maximum operator safety
- Heavy duty construction – heavy duty bearings, steel, and frames are used to withstand the most rugged of operating conditions

- Operator Health & Safety (OHS) – having the press at a comfortable working height, helps reduce OHS concerns and eliminate operator back complaints
- Quality worldwide components – only high-quality components such as; IFM, Lenze, and Eaton have been used and are available worldwide
- Minimal installation time – put in position, install perimeter fencing and light curtains, connect air and electricity, then it is ready to go

\*Jack Jig only

# CONVEYING

Eliminate bottlenecks, error and potential injury with our scalable and upgradable custom conveying and stacking systems.

## VEKTA STAKPRO FRAME



### / TOP VIEW

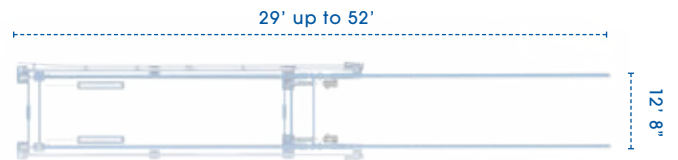

### / SIDE VIEW

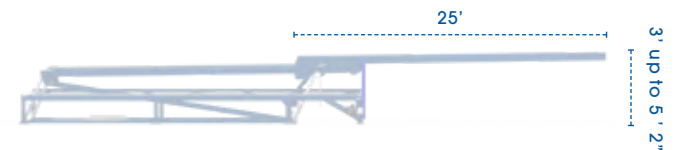

### / SUMMARY

The Vekta StakPro Frame is placed at the end of a framing line (indoors or outdoors) and has two arms that lift the assembled frames and stack them – all at the touch of a button.

Remove injury risk and manual requirements for automated frame delivery and stacking.

Available in multiple model options.

### / SPECIFICATIONS

Model options	Standard Heavy Duty Finishing Table Integrated
Safe working load	200 lbs - 1500 lbs (based on model)
Cycle time	45 secs to 90 secs (max)
Integration options	Gravity infeed, Automated Chain Drives (with backstops), Integrated Finishing Table
Automation options	Full Automation (requires Vekta Chain Drives), One-Touch Automation, Remote Operation + Control

### / FEATURES

- Removes the hazardous manual handling task and the risk for one or many people
- Scalable delivery, finishing and stacking solutions that focus on speed, efficiency and increased plant productivity

- Modular system option including integrated and stand-alone finishing tables, idle rollers, chain drives, and automated stacking

### / OPTIONS

- Control: manual operation via remote pendant and/ or automation kit
- Can be integrated into current systems for fabrication

- Heavy duty models for larger and heavier panels available



**/ CONVEYING**

**VEKTA**  
**FINISHING TABLES**

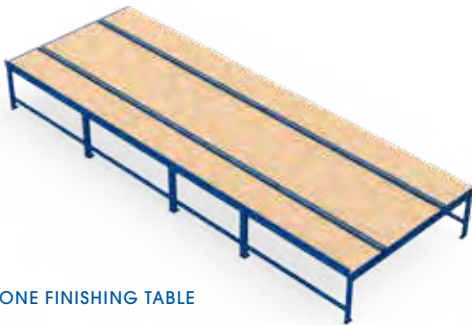

**/ STANDALONE FINISHING TABLE**



**/ STAKPRO FRAME WITH FINISHING TABLE INTEGRATED**

**/ FEATURES**

- Pneumatic pop-up rail facilitate frame progression with minimal manual handling
- Built in air connections for pneumatic tools
- Each table designed and built to suit your plant layout and needs
- Progress frames once completed with little to no manual handling (and no overhead cranes)
- Add a powered chain line with backstops to add automation and control to your framing line, you decide when your next frame is delivered
- Multiple options for stacking and line control and extended safety measures can be installed at any time

**/ FEATURES**

- Both the StakPro Frame and a Finishing Table combined
- Save precious floor space by combining two major parts of your fabrication line
- Stack your frames / panels as soon as they are complete with no manual handling
- Can be setup with 'one-touch' automation



**/ WATCH**

- Scan the QR code to the right to see Vekta's Frame Conveying Solutions in action!

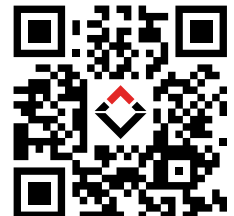



**/ CONVEYING**

**VEKTA  
STAKPRO TRUSS**



**/ TOP VIEW**

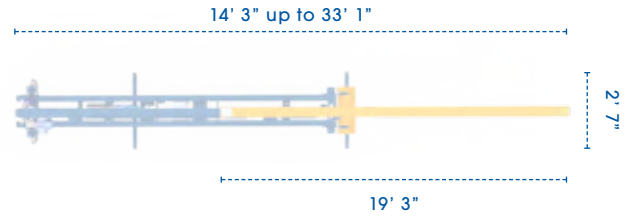

**/ SIDE VIEW**



**/ SUMMARY**

Remove the need for wasting time and precious staff on manual handling work that can be done more safely and efficiently by the StakPro Truss.

Easy to install, maintain and operate with variable levels of automation to suit your operational needs.

**/ SPECIFICATIONS**

Safe working load (per boom)	175 lbs
Cycle time	25 - 45 secs
Model options	External – standalone Internal – rail mounted
Number of booms per bay	1 minimum - 4 maximum typical

**/ FEATURES**

- Removes the hazardous manual handling task and the risk for one or many people
- Scalable delivery, finishing and stacking solutions that focus on speed, efficiency and increased plant productivity

- Modular system – add it to existing rollers or use the our Smart Roller Conveyor for complete automation

**/ OPTIONS**

- Manual operation via remote pendant and/or automation kit
- Interior or exterior options

- Integration options – Smart Roller Conveyor (SRC), standard rollers, Stak Roller, Truss Transfer



**/ CONVEYING**

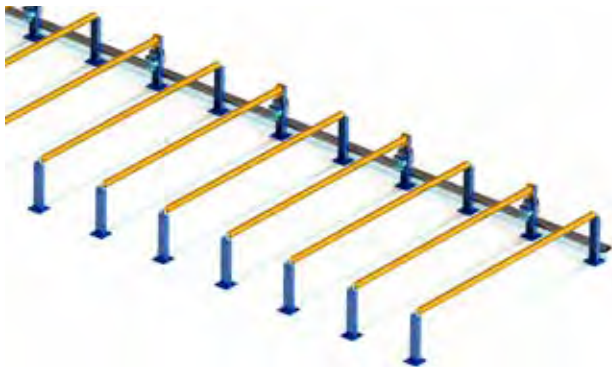

**/ TOP VIEW**

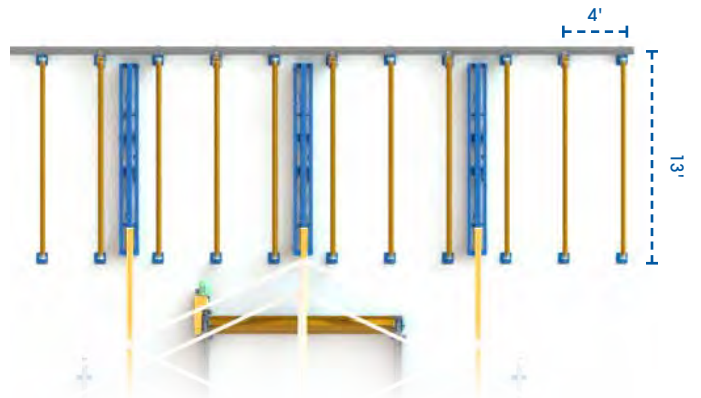

**/ SUMMARY**

The SRC (Smart Roller Conveyor) automatically moves your trusses to the center of the required bay for stacking.

When integrated with upstream systems, SRC knows exactly which bay each truss needs to be delivered to.

The use of a handheld pendant allows the operator to perfect positioning and handle stacking at multiple bays making the process safer, easier and more efficient.

**/ SPECIFICATIONS**

Width – roller length (truss can be wider)	13'
Height – ground to top of roller	2' 9" (Typical)
Length – roller conveyor line	To suit layout – roller conveyors typically spaced at 4'
Roller drive arrangement	Every second roller is driven by its own motor

**/ FEATURES**

- Faster, safer, easier and more efficient than manual transfer
- Designed to suit your layout
- Every second roller is driven by its own motor

- Controlled by handheld remote
- When integrated with upstream systems, SRC knows exactly where each truss needs to be delivered to

**/ OPTIONS**

- Fully customizable automation at the design stage including zone control, multiple bays, auto-stacking, collision avoidance, upstream integration, safety systems

**/ WATCH**

- Scan the QR code to the right to see Vekta's Truss Conveying Solutions in action!





**/ CONVEYING**



**/ TOP VIEW**

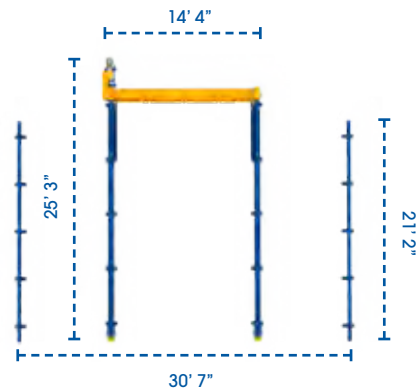

**/ SUMMARY**

Vekta’s Truss Transfers are a heavy-duty chain conveyance system designed to move full stacks of trusses.

When a stack of trusses is complete, the Truss Transfers move the stack out of the way immediately to eliminate bottlenecks at the stacking station .

**/ SPECIFICATIONS**

Safe Working Load (SWL)	5500 lbs
Height – ground to top of chain	1’ 2”
Transfer speed	1 ft/sec

**/ FEATURES**

- Eliminates bottlenecks with immediate truss transfer
- Takes time pressure off forklift operators
- Remote control movement at the touch of a button
- Extremely durable – heavy duty chain conveyance system designed for full stacks and external conditions
- Simple and reliable to maintain and repair

**/ OPTIONS**

- Perfect for integration with the Vekta Smart Roller Conveyor and StakPro Truss systems





**/ CONVEYING**

**VEKTA  
STAKROLLER**



**/ TOP VIEW**

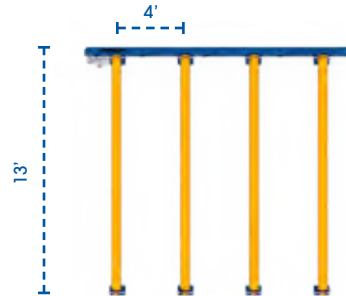

**/ SUMMARY**

With Vekta's StakRoller, utilize or recapture precious floorspace whilst increasing your productivity and eliminating bottle necks.

The StakRoller keeps truss stacks in the optimal orientation for picking up with a forklift.

**/ SPECIFICATIONS**

Weight limit (60ft span)	10,000 lbs
Speed	1' 7" per sec
Max. stack height	40 trusses
Rollers per set	4
Max. number of rollers	Unlimited

**/ FEATURES**

- Can be built to any length or extended later, conveniently built in bays to facilitate scaling and maintenance
- Retractable reaction posts allow apex inverted stacking and rolling of trusses

- Allows for on-the-spot strapping of trusses, moving them quickly and making room for the next set

**/ OPTIONS**

- Set up multiple bays downstream to organize your flow and truss placement
- Extra safety features available upon request and can be installed at a later date
- Potential for single button operation - systems rolls trusses and prepares for the next one

**/ WATCH**

- Scan the QR code to the right to see Vekta's Truss Conveying Solutions in action!

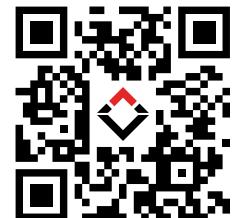

# THE VEKTA DIFFERENCE

## / SUPPORT SOLUTIONS

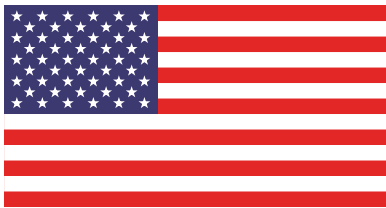

ENGINEER SERVICE & SUPPORT

### / SUMMARY

Vekta understand that automated machinery in a Truss and Frame plant can become your best team member.

If your saw is down, production, deadlines and reputation can also suffer.

At Vekta, nothing takes a higher priority than a customer with a technical problem.



### / INDUSTRY LEADING SERVICE & SUPPORT

- Spare parts held in Minneapolis, Perth, Melbourne, and Auckland
- Parts can be dispatched on the same day as ordered
- Online and phone remote support available no matter where you are located
- Dedicated customer support team
- Post-install consultation to ensure you are getting the most out of your equipment
- Technicians and Engineers who receive extensive training on all Vekta equipment

### / VEKTA RESCUE: THE ALWAYS AVAILABLE ONLINE GUIDE

- Step by step information for problems with software, cutting issues, optimization, printing
- Training checklists
- FAQ's
- New information is continuously being added to support all Vekta products
- Maintenance procedures – daily, weekly, monthly



**/ OUR TEAM**



**/ ED SERRANO - MANAGING DIRECTOR**

Ed Serrano is the Managing Director of Vekta Automation in Australia and Vekta USA in North America. Born in the USA, he moved to Australia to study Mechatronic Engineering at Curtin University, graduating with Honours in 2004.

Ed's career with automation began with the Razer Linear Saw at PFP Technologies. In 2009, he purchased the IP and rights to the Razer saw and formed Vekta Automation.

Ed has over 20 years' experience with industrial automation projects specifically for the Truss and Frame industry.

With a solid understanding of the conditions and needs of truss plants and his experience in industrial automation, he has helped many plants improve their production and business through automation.



**/ AARON BAHNER - GENERAL MANAGER, USA**

Aaron is the General Manager of Vekta USA. An intelligent and passionate leader, Aaron loves to bring people and ideas together, with his knack for getting the most from his teams and peers.

After graduating from The University of North Dakota in 1997 with a Masters of Science in Industrial Technology his career led him to expanding roles in product and equipment design and manufacturing.

At Vekta, Aaron has furthered his love for team and business leadership developed through years of career experience in heavy industry management.



**/ VEKTA'S TEAM**

Vekta's team know what it means to be competent and accountable. They know when to act and when to seek help. They know how to best support you and your business.

Vekta's team have an industry-leading reputation for consistently deliver high-quality service to customers in different parts of the globe.



# VEKTA

ADVANCED AUTOMATION

YOUR AUTOMATION PARTNER

## AUTOMATE WITH VEKTA TO:

- ENHANCE EFFICIENCY
- BOOST PRODUCTION
- MINIMIZE WASTE
- REDUCE REDUNDANCIES
- IMPROVE SAFETY
- REDUCE OVERHEADS
- FUTURE PROOF

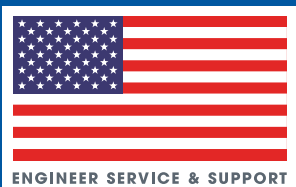

VEKTAUSA.COM