

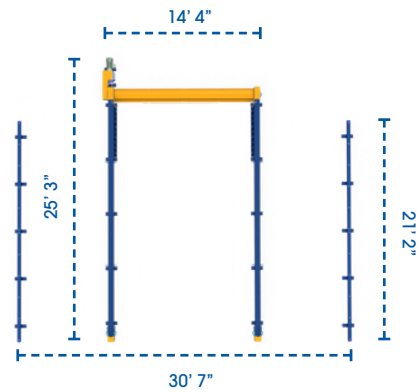

/ CONVEYING



/ TOP VIEW



/ SUMMARY

Vekta's Truss Transfers are a heavy-duty chain conveyance system designed to move full stacks of trusses.

When a stack of trusses is complete, the Truss Transfers move the stack out of the way immediately to eliminate bottlenecks at the stacking station .

/ SPECIFICATIONS

Safe Working Load (SWL)	5500 lbs
Height - ground to top of chain	1' 2"
Transfer speed	1 ft/sec

/ FEATURES

- Eliminates bottlenecks with immediate truss transfer
- Takes time pressure off forklift operators
- Remote control movement at the touch of a button
- Extremely durable - heavy duty chain conveyance system designed for full stacks and external conditions
- Simple and reliable to maintain and repair

/ OPTIONS

- Perfect for integration with the Vekta Smart Roller Conveyor and StakPro Truss systems